

B8M4418S23

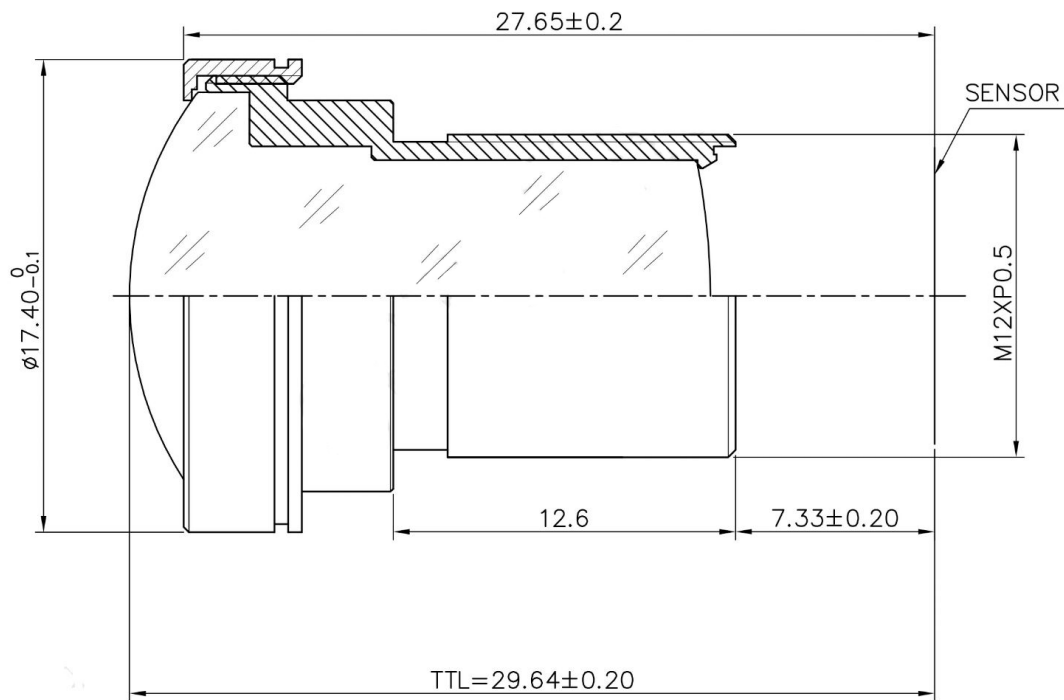

The S-Mount lens Lensagon B8M4418S23 is suitable for current sensors up to 8.00 megapixel with an image format of 2/3 inch. It is characterized by a particularly high light intensity.

Technical Data

Mount	S-Mount
Sensor	2/3 inch
Focal Length	4.41 mm
Aperture	1.80
Angle of View	D:139.60° H:120.40° V:66.40°
Megapixel	8.00 MP
IR Cut Filter	No
TV Distortion	-18.00 %
Weight	8.00 g
Chief ray angle	11.00 °
Typ	Standard



Light Sensitive



8 Megapixel

